



Palmako

LEMEKS GROUP

DESIGN STATEMENT

IRIS CABIN (11.1M²)

3.9M X 3.0M

FR44-4132-2

tradetested

A20130
23 NOVEMBER 2020

TRADE TESTED LOG CABIN GARDEN HOUSE IRIS (3.9M X 3.0M)

Trade Tested import kitset log cabin garden houses made of spruce timber that can be constructed on site. Various cabin sizes and footprints are available. This design statement is specific to the Log Cabin Garden House Iris (11.1m²).



Richards Consulting Auckland Limited has been engaged by Trade Tested to prepare a standard design statement on the maximum site loadings (wind, earthquake and snow) which the cabins can withstand.

CABIN STRUCTURAL SYSTEM

The cabin is a timber structure built up from spruce timber logs with a pitched timber roof structure. The roof purlins resist gravity, wind and snow loads on the structure. The roof is non-trafficable and as such is not designed to carry live loads. The roof loads are supported by the timber log walls. Wind and snow loads have been calculated as per AS/NZS1170.2 and AS/NZS1170.3 respectively. Sectional capacities of the timber members have been determined using Timber Structures NZS3603: 1993.

The garden shed lateral load resisting system is provided by storm braces bolted to the external walls. The log walls span between perpendicular walls (or door mullions on the front wall) to resist the wind face loads on the structure and transfer the loadings into the storm brace system. The door mullions are 50x5 equal angles (EA) which are an addition to the cabin kitset. The mullions are to be installed as per the Palmako construction detail attached at the end of this design statement.

The cabin will be founded on a concrete slab with perimeter footings. The slab should be 100mm thick and reinforced with SE62 steel mesh in accordance with NZS 3604:2011. Refer to the typical foundation slab detail attached. The cabin foundation logs should be fixed down to the concrete slab.

The design of the log cabin garden shed within this document is in compliance with the New Zealand Building Code (NZBC) section B1.

SERVICEABILITY CRITERIA

The following deflection limits were used for the following elements within the Log Cabin Garden House Iris (3.9m x 3.0m):

- Lateral deflection of wall logs: L/150
- Roof purlins: L/200

DESIGN LOADS AND LOAD CASES

The maximum allowable site loads for the log cabin garden shed (Importance Level 2) are:

- Wind: 'Medium' Wind Zone (32m/s)
- Earthquake: EQ Zone 3, Soil Class D or EQ Zone 4, Soil Class C
- Ground Snow Load: 1.5kPa

The site loads can be determined from:

- Wind: Local council wind maps found on the relevant council websites or BRANZ.co.nz
- Earthquake Zone can be determined from BRANZ.co.nz
- Snow Load: Maximum allowable altitude in the following regions:
 - o Northland, Auckland, Waikato and Bay of Plenty: No altitude limit.
 - o Gisborne, Taranaki, Hawke's Bay, Manawatu-Wanganui, Wellington: 600m
 - o West Coast: 600m
 - o Tasman, Nelson and Marlborough: 600m
 - o Canterbury: 200m
 - o Otago and Southland: 300m

The following design load cases have been applied to the log cabin garden shed members:

- $0.9G + W_u$ (ULS for wind uplift)
- $1.2G + S$ (ULS downward load case)
- $1.2G + EQ$ (ULS for lateral load case)
- $0.9G + W_{lat}$ (ULS for lateral load case)
- W_s (SLS for wind related deflection)

DESIGN LIMITATIONS

The following design assumptions apply to the design statement:

- The member sizes used will be the same as those checked in the design.
- Spruce timber will be used with an $E = 8\text{GPa}$ and $f_b = 16\text{MPa}$.
- The structure will be constructed as per the Palmako construction manual.
- The structure will be built on a site that meets the requirements of 'Good Ground' as per NZS3604:2011. 'Good Ground' is determined as firm natural soils on a site with no site stability issues, expansive soils, organic soils (peat) and low risk of liquefaction.
 - o In the Auckland region, expansive soils are reasonably common. Auckland Council practice note AC2208 stipulates a minimum embedment depth of 450mm below cleared ground level for foundations. As such, foundations constructed for Palmako

log cabins in the Auckland region should have a minimum embedment depth of 450mm below cleared ground level.

- No modifications are made to the structure (unless authorized in this design statement).
- The cabins are not to be installed within Corrosion Zone D (sea-spray zone). Refer to BRANZ.co.nz for locations.
- The cabin has been designed for a 15-year design life.

BUILDING CONSENT EXEMPTION REQUIREMENTS

The New Zealand Building Act currently allows for single-storey detached buildings up to 30m² in floor area with prefab or kitset components to be constructed without a building consent provided the following requirements are met.

- The building does not contain sanitary facilities or facilities for the storage of potable water.
- The building does not include sleeping accommodation, unless the building is used in connection with a dwelling.
 - If the building includes sleeping accommodation, smoke alarms are required to be installed.
- The building does not include any cooking facilities.
- The building is situated further than its own height from any residential building or to any legal boundary.

DESIGN EXCLUSIONS

The following items are specifically excluded from this design statement:

- Weather and waterproofing of the shed.
- Electronic services to the cabin.
- Fire and smoke alarms.

MATERIAL AND SECTION PROPERTIES

The log cabins will be made from spruce timber members.

The structural member properties are as follows:

114x44mm wall logs	$I_y = 0.81 \times 10^6 \text{ mm}^4$
50x5 EA door mullions	$I_x = 0.163 \times 10^6 \text{ mm}^4$
140x70mm roof purlins	$I_x = 16.0 \times 10^6 \text{ mm}^4$
Concrete foundations	$f'_c = 20\text{MPa}$
Spruce timber	$E = 8\text{GPa}$ $f_b = 16\text{MPa}$
Steel	$E = 200\text{GPa}$ $f_y = 300\text{MPa}$

DURABILITY

The structure has been designed with a durability for the life of the structure (15 years with maintenance) as outlined in B2. The finished floor level of the structure is to be 225mm above adjacent finished ground levels (E1).

Prior to construction of the garden shed, the timber elements should be treated with an appropriate wood preservative i.e. a borate-based product (for example TimberSafe Multi-purpose Wood Preservative) or a Copper Naphthenate based product (Metalex Green Concentrated Timber Preservative). After construction, the garden shed should be painted or stained, with the chosen coating reapplied as per the product specifications.

DESIGN STATEMENT NOTES

The person or people installing the garden shed should have a good understanding of the construction techniques required and abide by the following:

- Only the attached connection details shall be used.
- No substitution with the products included in this design statement is permitted.
- The owner should refer to their local district council plan to ensure they meet planning requirements including, but not exclusive to, site coverage, boundary setbacks, recession planes, etc.
- The timber products used for construction should be treated with an appropriate wood preservative.
- For the log cabin to suitably resist the specified site loads, the additional 50x5 EA mullions must be installed as per the Palmako construction detail.

COPYRIGHT

This design statement is the property of Richards Consulting Engineers Limited and must not be copied or reproduced without permission.

APPENDICIES

- PS1
- Foundation Detail
- Palmako Construction Detail for mullions.

REFERENCES

- AS/NZS1170: 2011
- NZS3603: 1993
- NZS3604: 2011

Site Loadings Checklist					
Maximum Wind Zone	Medium		Y ()	N ¹ ()	
EQ Zone and Soil Class	Zone 3	Soil Class D	Y ()	N ()	NA ² ()
	Zone 4	Soil Class C	Y ()	N ()	NA ()
Snow Region and Altitude	Northland Auckland Waikato Bay of Plenty	No altitude limit	Y ()	N ()	NA ()
	Gisborne Taranaki Hawke's Bay Manawatu-Wanganui Wellington	600m	Y ()	N ()	NA ()
	West Coast	600m	Y ()	N ()	NA ()
	Tasman Nelson Marlborough	600m	Y ()	N ()	NA ()
	Canterbury	200m	Y ()	N ()	NA ()
	Otago Southland	300m	Y ()	N ()	NA ()
	Good Ground ³		Y ()	N ()	
Distance from other buildings and legal boundaries ⁴	> 2.65m		Y ()	N ()	
¹ If 'no' (N) ticked, then log cabin is not suitable for the proposed site. ² If another option has been ticked 'yes' (Y), NA may be ticked. ³ With consideration of Auckland Council practice note AC2208. ⁴ For protection against fire spread, the cabin must be situated further than its own height from another residential structure or from any legal boundary. Note: There are other local planning requirements that will also have to be reviewed.					



New Zealand
Institute of Architects
Incorporated



Building Code Clause(s).....B1

PRODUCER STATEMENT – PS1 – DESIGN

(Guidance on use of Producer Statements (formerly page 2) is available at www.engineeringnz.org)

ISSUED BY:.....Richards Consulting Engineers Limited(RCE)
(Design Firm)

TO:..... Trade Tested Limited NZ
(Owner/Developer)

TO BE SUPPLIED TO:..... All Territorial Authorities within New Zealand
(Building Consent Authority)

IN RESPECT OF:... Palmako Timber Log Garden Shed Iris 11.1m² Cabin
(Description of Building Work)

AT:.....
(Address)

Town/City: **LOT** **DP** **SO**
(Address)

We have been engaged by the owner/developer referred to above to provide:
.....engineering design of the Palmako Log Cabin design tables.....
(Extent of Engagement)

services in respect of the requirements of Clause(s) ...B1of the Building Code for:
All or Part only (as specified in the attachment to this statement), of the proposed building work.

The design carried out by us has been prepared in accordance with: AS/NZS 1170:2011, NZS 3603:1993 and;

- Compliance Documents issued by the Ministry of Business, Innovation & Employment.....B1/VM1 & B1/VM4.....or
(verification method / acceptable solution)
- Alternative solution as per the attached schedule.....

The proposed building work covered by this producer statement is described on the drawings titled:

... Installation Manual, Log cabin FR44-4132-2.....;
together with the specification, and other documents set out in the schedule attached to this statement.

On behalf of the Design Firm, and subject to:

Site verification of the following design assumptions:

- (i) site loadings have been calculated correctly
- (ii) all other assumptions stated within the design statement have been satisfied/accounted for

I **believe on reasonable grounds** that a) the building, if constructed in accordance with the drawings, specifications, and other documents provided or listed in the attached schedule, will comply with the relevant provisions of the Building Code and that b), the persons who have undertaken the design have the necessary competency to do so. I also recommend the following level of construction monitoring/observation:

CM1 CM2 CM3 CM4 CM5 (Engineering Categories) or as per agreement with owner/developer (Architectural)

I,Nicholas Baker..... am: CPEng ...1016657.....# Reg Arch#
(Name of Design Professional)

I am a member of : Engineer New Zealand NZIA and hold the following qualifications:.....BE(hons).....

The Design Firm issuing this statement holds a current policy of Professional Indemnity Insurance no less than \$200,000*.

The Design Firm is a member of ACENZ:

SIGNED BYNicholas Baker.....(signature).....
(Name of Design Professional)

ON BEHALF OFRichards Consulting Auckland Limited.....Date...20 November 2020 This PS1 is valid for 1 year only.....
(Design Firm)

Note: This statement shall only be relied upon by the Building Consent Authority named above. Liability under this statement accrues to the Design Firm only. The total maximum amount of damages payable arising from this statement and all other statements provided to the Building Consent Authority in relation to this building work, whether in contract, tort or otherwise (including negligence), is limited to the sum of \$200,000.*

This form is to accompany Form 2 of the Building (Forms) Regulations 2004 for the application of a Building Consent.

THIS FORM AND ITS CONDITIONS ARE COPYRIGHT TO ACENZ, ENGINEERING NEW ZEALAND AND NZIA

Reference:	A20130	By:	JDS
Date:	AUG 2020	Sketch:	

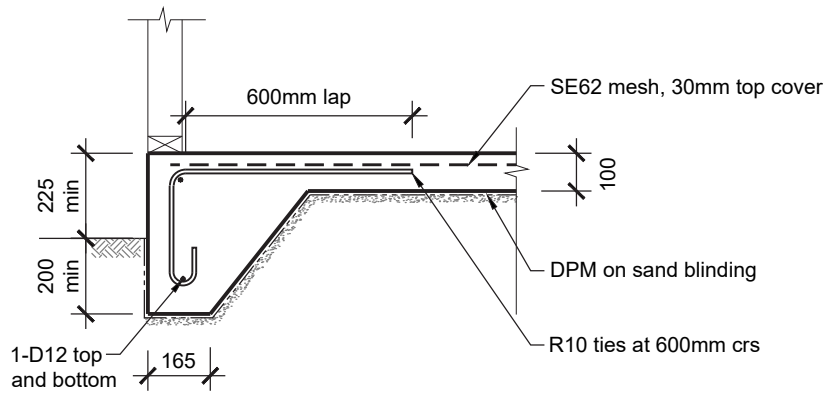

001 CONCRETE PERIMETER FOOTING
SCALE 1:20

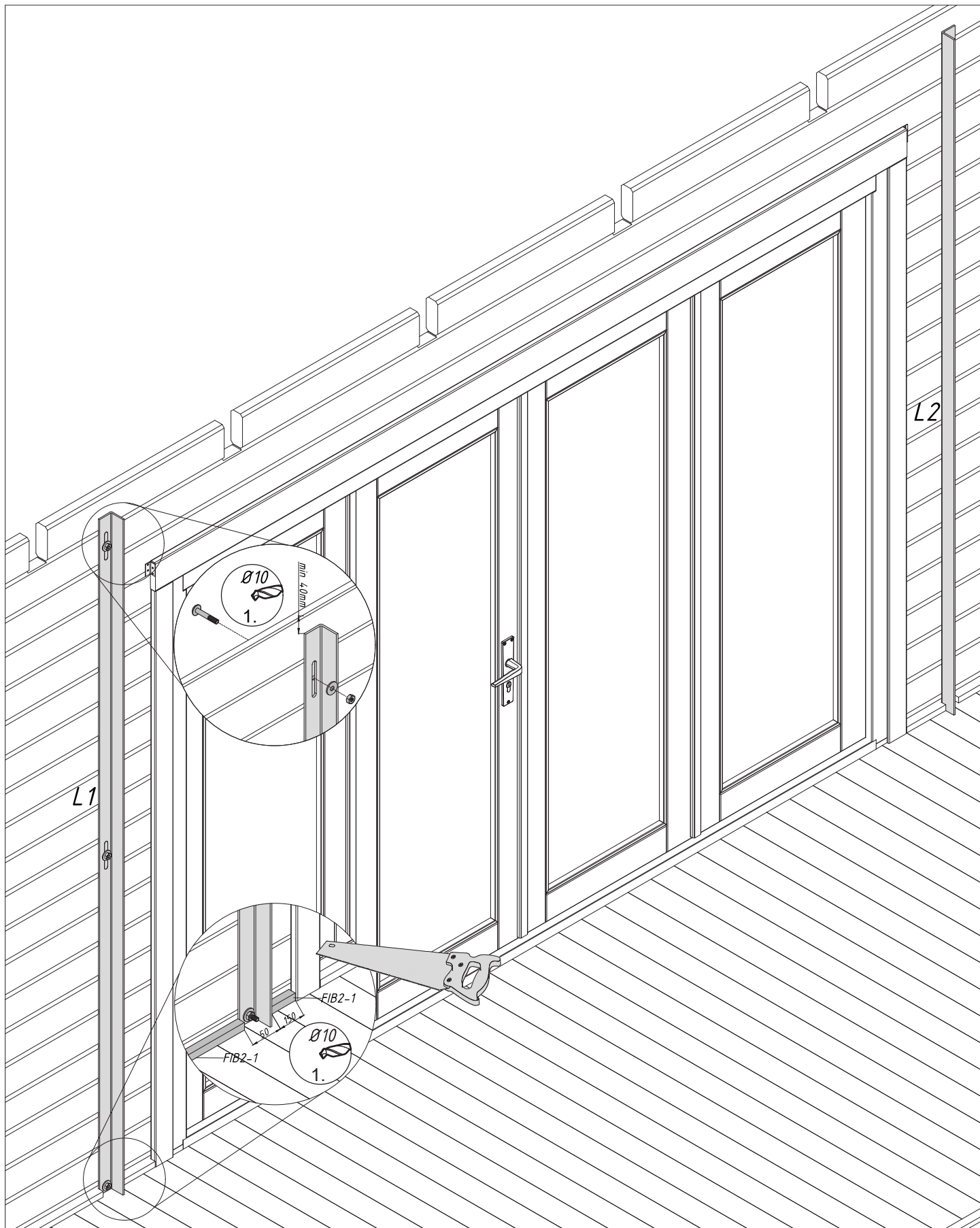

Pos	SPECIFICATION-STÜCKLISTE-NOMENCLATURE-ELEMENTI-ESPECIFICACIÓN	Pcs	Profile (mm)	Length (mm)
M10x60	Bolt -Schloss-schraube -Boulon- Bullone- Perno- M10x60mm	6		
M10	Nut- Schraubenmutter- Écrou- Dado- Tuerca- M10mm	6		
10x30	Washer- Dichtscheibe- Joint- Rondella- Arandela- 10x30mm	6		

L1

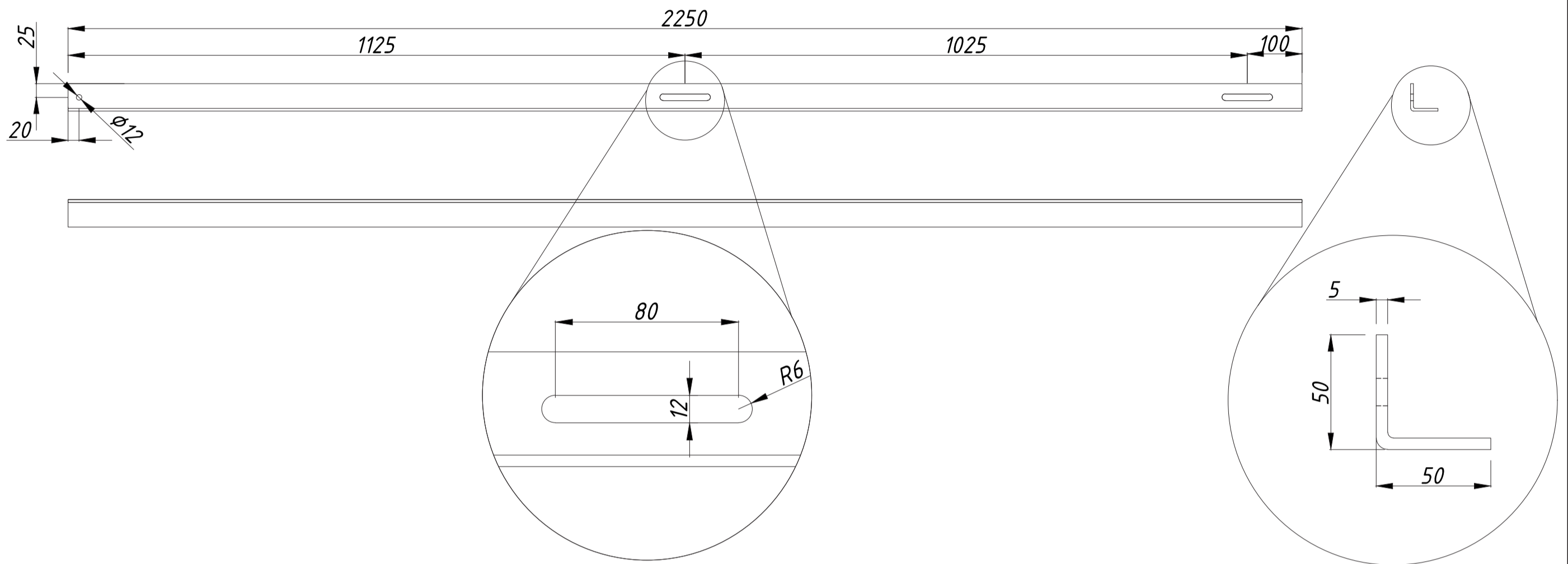

L2

